

GLR43303-12, GLR43304-12, GLR43303-24, GLR43304-24

Multi-Channel 433MHz Gigalink Receiver

Features

- Wide supply connection – 11.0 to 14.0 Volts AC/DC for GLR43303/0412 or 21.0 to 28.0 Volts AC/DC for GLR43303/0424.
- Highly sensitive receiver input stage. When used with GLT433.... series transmitters and an ANT433S antenna, an operating range of 350 metres (980 ft) is possible.
- Three or four relay outputs. All outputs can be operated simultaneously.
- Crystal controlled for high stability and performance.
- Uses micro-controller technology that can be re-programmed to suit unique applications.
- Momentary, flip-flop and latching output modes is user selectable.



GLR4330312	3-channel, 12V Relay Outputs
GLR4330324	3-channel, 24V Relay Outputs
GLR4330412	4-channel, 12V Relay Outputs
GLR4330424	4-channel, 24V Relay Outputs

Applications

- Automatic gates, security, timer controlled outputs and simple on/off functions

Description

The GIGALINK™, is the most advanced Remote Control technology available in the world today. GIGALINK™ is an invention that has revolutionised the entire Remote Control technology including Elsema's earlier version of FMT- ... and FMR- ... series. The GLR.... series state-of-the-art invention brings a new dimension in the world of Remote Control technology in domestic, commercial and industrial applications.

The innovative microcontroller technology replaces the traditional dip switch coding which eliminates any possible code grabbing. Special features such as over four billion code combinations, ability to program any number of transmitters to any of the receiver outputs, four user selectable modes, dual conversion superhet and operational over a wide voltage range all adds up to the most advanced and secure Remote Control available.

The multi channel receivers are available with three or four channels.

Four billion codes

The user can easily change the code on all the channels. Momentary joining the two CC pins on the receiver board sets all channels to one random code. One of 4,294,967,296 possibilities is selected.

Code Programming - Single

During single code programming, the 4-way dip switch selects the channel to be programmed. The table below shows the setting to select a different channel.

Dip Switch		Channel
1	2	Output Relay
OFF	OFF	1
ON	OFF	2
OFF	ON	3
ON	ON	4

After selecting the correct channel, the receiver channel is ready to be single code programmed.

Follow the steps outlined in the receivers instruction sheet titled single code programming to complete the code programming.

Code Programming - Channelised

If all the receiver channels are to be programmed onto a multi channel transmitter, then follow the steps outlined in the receivers instruction sheet titled channelised code programming. This does not require the user to set the 4-way dip switch

since all receiver channels will be programmed sequentially onto the transmitters channels. The receiver power must be connected when single or channelised code programming. When programming is completed and the GIGALINK cable is removed from the multi channel receiver-coding socket, the 4-way dip switch is used to select different output modes. This is described below.

Different Modes for the Output

Modes are user selectable from the 4-way dipswitch. Dipswitch 1 corresponds to relay channel 1 and dipswitch 2 corresponds to relay channel 2.

Momentary Mode	If the dipswitch is “off” the relay will be in momentary mode.
Flipflop Mode	If the dipswitch is “on” the relay will be in flipflop mode.
Latching	If latching is required (Relay stays on until power is removed) the latching link should be inserted and soldered into the two holes to the right of the 4-way dipswitch. This will enable all relays to latching.

AC/DC Supply and Antenna

AC/DC power supply and antenna is connected via a screw-type terminal block. Do not connect the supply to the 2.5-mm coding socket since connection may damage the microcontroller.

Unique Code System

The microcontroller EEPROM allows large volume users to have a unique code. This enables Elsema to offer everyone “your own” radio control.

Case

The three or four-channel receiver is supplied without a case, this allows the receiver to be integrated according to your needs. Elsema has available a Quick Mount bracket which enables easy mounting to walls, roof etc.

Products in the Range

				
GLR43301 1-Channel	GLR43301240 1-Channel, 240V	GLR43302 2-Channel	GLR4330312 GLR4330324 3-Channel, 12 / 24V	GLR4330412 GLR4330424 4-Channel, 12 / 24V
				
GLR43308 8-Channel	GLR4330812 GLR4330824 8-Channel, 12 / 24V Relay Output	GLR43301SS 1-Channel, Solid State Output	GLR43302SS 2-Channel, Solid State Output	GLR433CS 1-Channel, Code Switch

Technical Data

Supply Voltage	GLR43303/4-12 : 11.0 to 14.0 VAC/DC GLR43303/4-24 : 21.0 to 28.0 VAC/DC Can use Elsema AC power pack (PP12 or PP24) Supply lines should be less than 3 metres long to comply with radio frequency authorities.
Current Consumption	GLR43303/4-12 : 10mA standby at 12VDC; 124 mA if all relays "ON" at 12VDC GLR43303/4-24 : 10mA standby at 24VDC; 70mA if all relays "ON" at 24VDC
Receiver Type	Single Conversion Superheterodyne
Receiving Freq	433.920MHz (Other frequencies available on request. Refer to the table below)
Type of Crystal	6.775MHz, Fundamental, 20pF, 30ppm
Operating Temperature Range	-5 to 50°C
IF Freq	320kHz
Selectivity	3dB at ±20kHz
Sensitivity	Better than 1.0uV (For output to switch on)
Type of Demodulation	Amplitude Shift Keying (ASK)
Decoding System	Microcontroller (32-bit word 4.29 x 10 ⁹ codes)
Code Combinations	4,294,967,296
Relay Contacts	GLR4330312/24 : Three change over relay outputs, each rated at 5 Amps/240 Volts GLR4330412/24 : Four change over relay outputs, each rated at 5 Amps/240 Volts
Connections	Screw type terminal block.
Antenna	50 ohms, 433.920 MHz Antenna or piece of approximately 690 mm of wire. If coaxial cable is used connect the shield to the minus on the terminal (Gnd).
Dimensions	130 X 70 X 20 mm
Mounting hole size	3.97 mm or 5/32"
Weight	GLR43303: 97 grams GLR43304 : 116 grams
Microcontroller	Can be re-programmed to suit your customised needs
Useable Transmitters	All Elsema Type 433MHz GLT-... series
Useable operating range	Up to 350 metres with proper 50 ohms, 433 MHz Antenna . Up to 200 metres with 690 mm long antenna wire. Antenna wire should be extended and away from metal. Ranges assume line-of-sight operation

Available Frequencies

SF2	433.664 MHz
SF3	433.408 MHz
SF4	433.152 MHz
SF5	434.688MHz
SF6	434.432 MHz
SF7	434.176MHz
SF8	433.792 MHz
SF9	434.304 MHz

Please quote Correct SF number when ordering transmitters on special frequencies.

Block Diagram

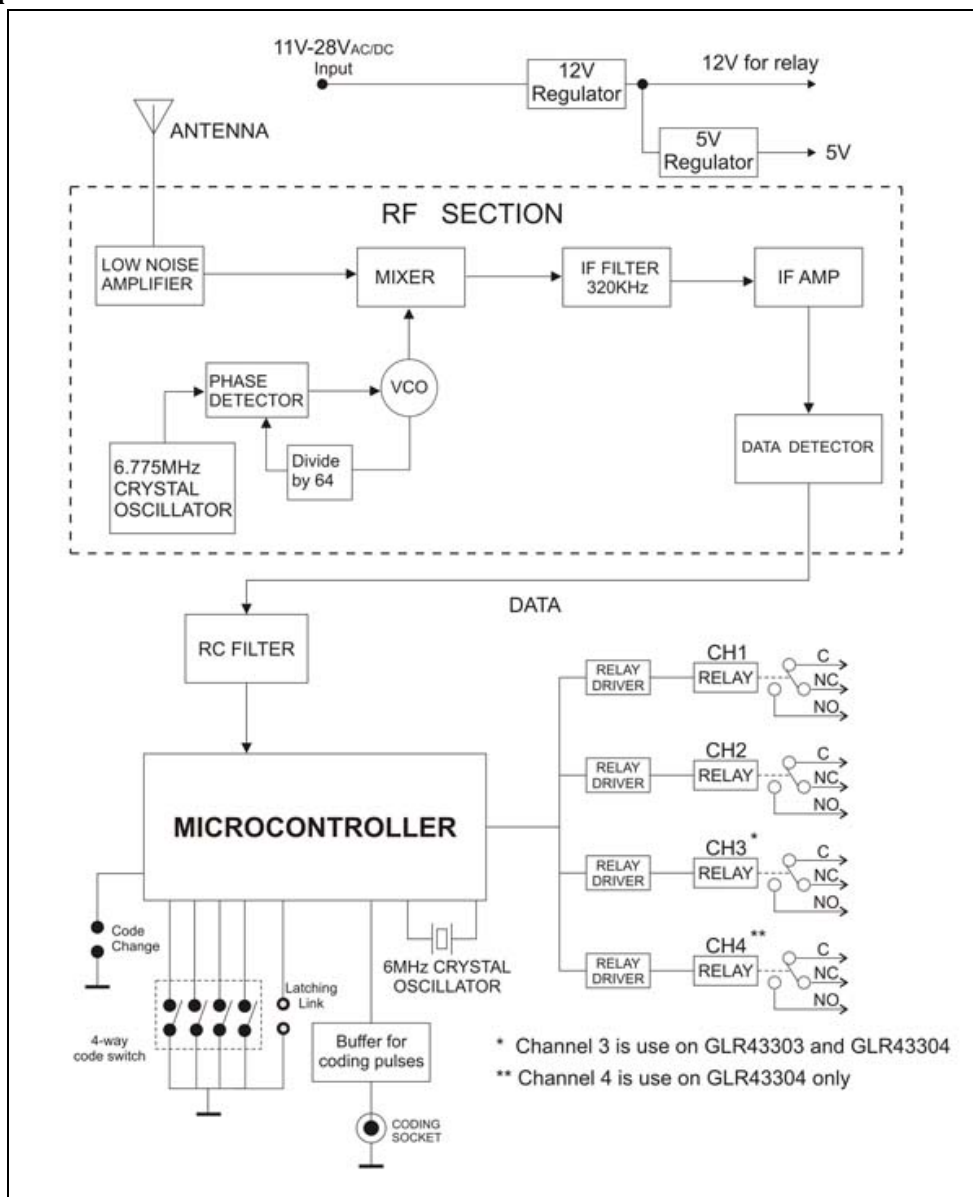

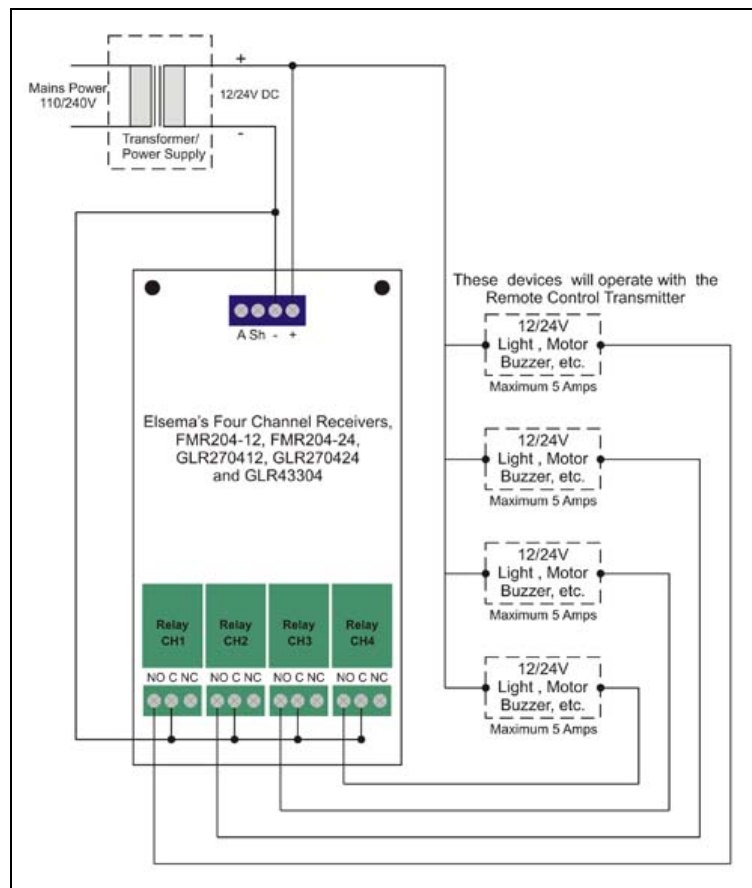
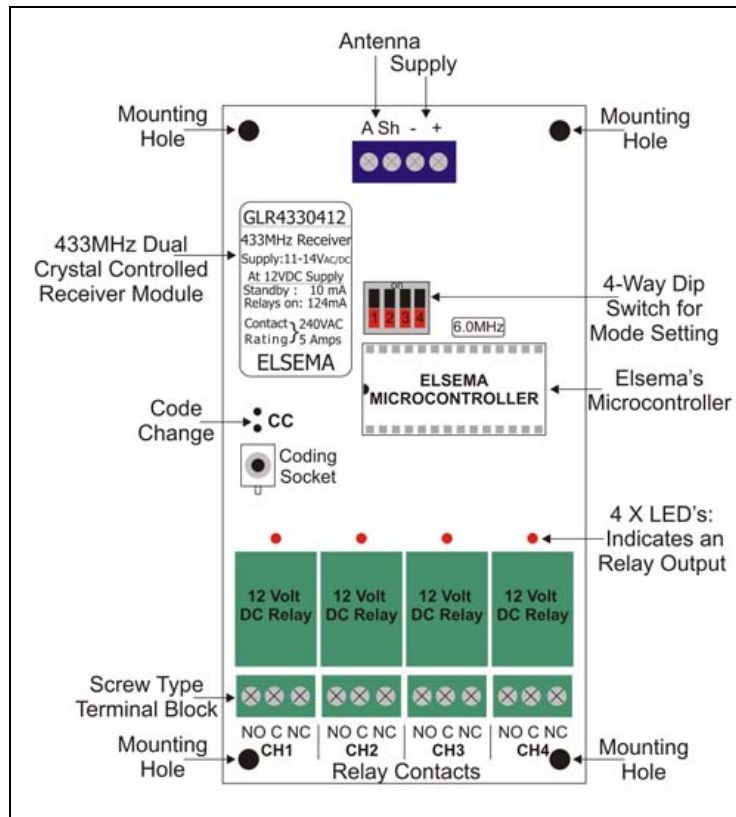

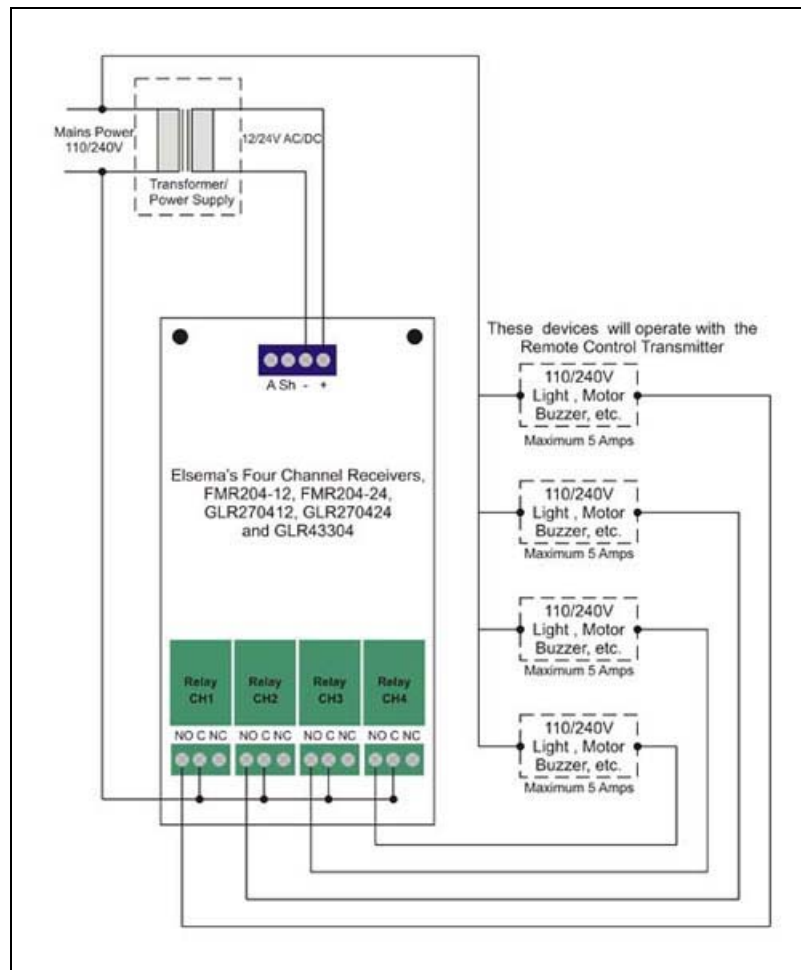

Manufactured by

Elsema Pty Ltd
 3/10 Hume Rd, Smithfield
 NSW 2164
 Ph: 02 9609 4668
 Fax: 02 9725 2663
 Website: <http://www.elsema.com>

Distributed by

